

Lithography

Polyester Litho Plates / Pronto Plates

Creating Your Image

Drawing Materials

Ball Point Pen, Sharpie Permanent Marker, China Marker, #5 Stones Litho Crayons, Photocopier Toner (Must be heat-set in an oven or on a hot plate at 225° for 10 minutes), india ink.



All of the materials listed above work very reliably, but the ball point pens should be allowed to dry for several hours or a day, before printing. Toner can be mixed 3 parts liquid to one part toner. Isopropyl alcohol works well, or water with a drop of dish soap or photo-flo to allow the powder to mix with the water. The toner can be fused to the plate by laying the plate on one or two sheets of newsprint on a hot plate, and covering it with a cover made out of aluminum litho plates to help trap the heat and bake the toner onto the plate. The toner is completely fused when it turns glossy and doesn't wipe off the plate.

Setting Up Your Plates: Plate Size vs. Image Size

To make printing easier, first mark out margins at least 1" wide on your plate within which you can draw your image. Although the plate size may be 12x18" for instance, it can be difficult to ink an image that covers almost the entire plate. You must keep at least 1" margins on each side, but it is recommended that you make them 1.5" wide. This means printing no larger than an 8x14" image on an 11x17" plate, or a 9x15" image on a 12x18" plate.

Creating Plates with Digital Images and a Laser Printer

Using Adobe Photoshop, InDesign and a laser printer you can easily scan and print images onto polyester plates. A 1200dpi laser printer such as an HP 5200, or a Xante printer will work best. However, it is best to make a few adjustments to your print settings to make polyester plates print easily and accurately at the press.

By default most laser printers will print images over 120 lines per inch. Lines per inch (lpi) is a measurement of how many lines of small varying sized halftone dots are used to create the illusion of a continuous tone image. Since printing these plates by hand requires more ink and pressure than offset printing, which is what these plates were intended for, we need to decrease the lpi to 75. If you did not do this, the ink sitting on top of all the very tiny halftone dots would likely run together, or 'bridge'. To prevent this from happening, lower the lpi to

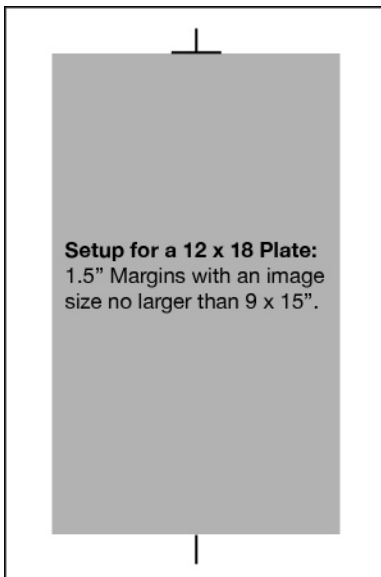

Mark off margins for the image on the back of your plate in graphite before drawing on it. You can also draw the T and Bar registration marks in pen or Sharpie for where you will position your paper.

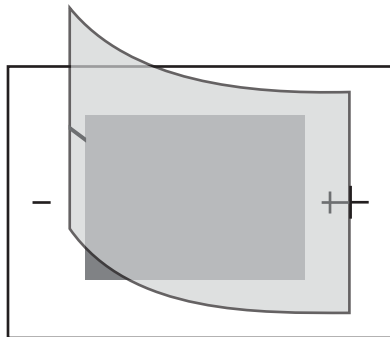
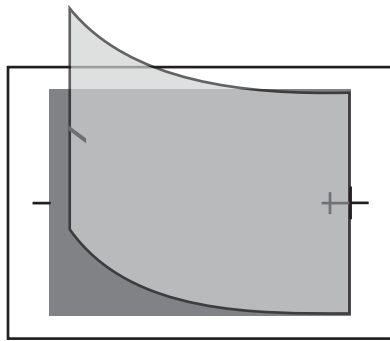

Set up for a bleed-format and a window-format print.

maintain a balance between the amount of ink that is needed to print and the space around the dots to hold water and repel the ink. As you gain more control over your printing, the easier it will be for you to print higher lpi images. 95lpi is high for hand printing, but can still be manageable.

Accurately printing your polyester litho plates on a laser printer requires the use of both Adobe Photoshop CS5 and InDesign. Your Photoshop file must be converted to Greyscale Mode (If you are printing color separations you will need a CMYK file, or a greyscale file with either Duotone settings applied, or one or more spot channels).

1. In InDesign, create a new document that is the same size as the polyester plate you will send through the laser printer.

2. Go to MB > File > Place... to select and place your image file in InDesign.

3. Once your image is positioned go to MB > File > Print.

Under Setup, select the Printer and Paper Size to match your polyester plate and printer.

4. Under 'Output', switch 'Color:' to Separations. 'Flip' your image Horizontally so it will print reversed. Turn off the printer icon next to Cyan, Magenta, and Yellow, so only the Black (Greyscale) plate will print. Set the Frequency for the black plate to 75 lpi and the angle to 45°.

5. Load you plate into the manual tray on your laser printer and click print.

If you are printing a Duotone, spot channels or a CMYK color separation, the angles are: Black/Darkest Color: 45°, Cyan/Next Lighter: 15°, Magenta/Next Lighter: 75°, Yellow/Lightest: 90°.

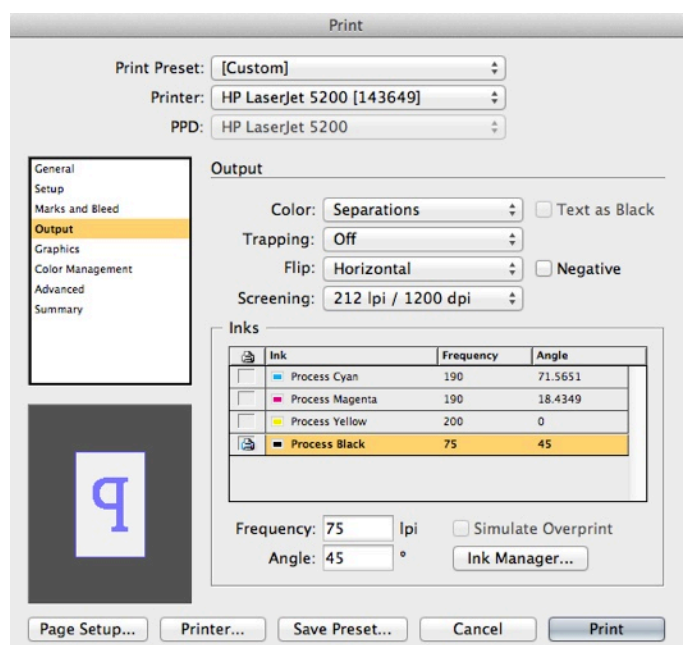
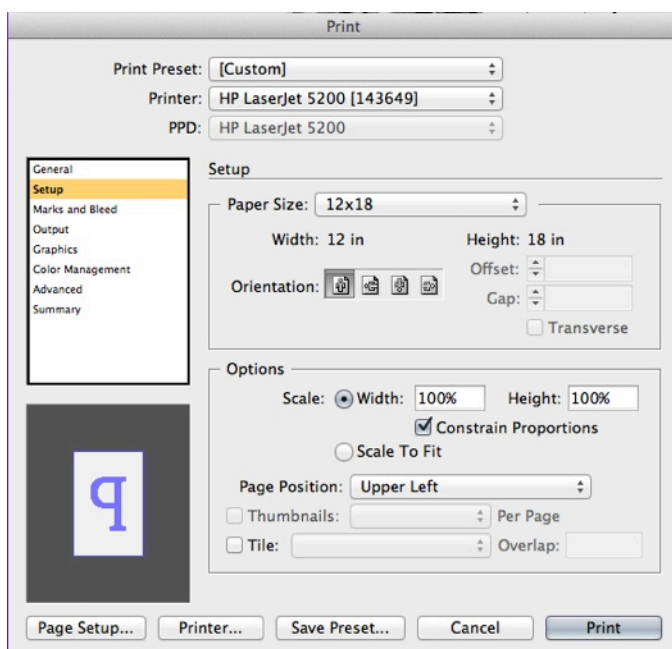

Laser Printers and Post-Fusing

Plates created from a laser printer can sometimes break down very quickly if the toner isn't sufficiently melted or fused to the plate. There are two methods that can be used to better secure the image on the plate. The first is to run the plate through the laser printer one or two more times, but without printing the image. This will allow the plate to run over the heating element in the printer again to better melt the toner to the plate. To do this, simply create a new layer in your document, fill it with white, and print it. The second method requires a hot-plate. Lay the plate on two sheets of newsprint and set them on the hot plate and, if possible, cover it with a lid made from old litho plates with the edges bent over to keep it off your polyester plate. Post-fusing your polyester plate will ensure a longer run from the plate without the image breaking down. The temperature should be approximately 225°, and can be baked from 10-20 minutes.

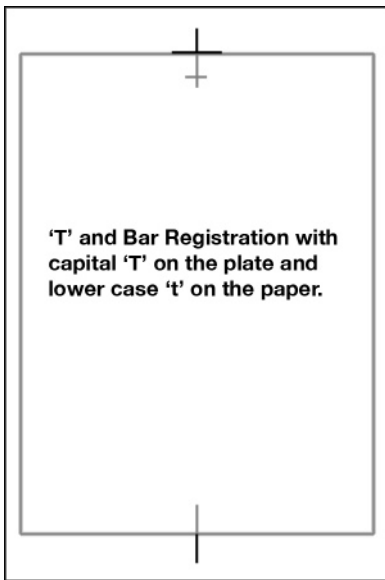

Setting Up to Print

Materials

Printing Paper	Newsprint	Two Bowls
Gum Arabic	Large Sponges	Felt & Toothpaste
Inking Brayers		

Lithography Inks & Modifiers: Black(Graphic #1796), Handschy Yellow, Magenta, Cyan, White, Tint Base/Transparent Base. Magnesium Carbonate or #8 Varnish.

General Setup

Prepare newsprint, and printing paper, making sure to add the 'T' and Bar registration marks on the back of the paper. Mix and modify your inks as needed and roll out your slab of ink with the brayer. Fill one bowl with about 1L water and about an ounce of Gum Arabic. This will help reduce the Ph of the water. Ideally, polyester plates work best with a dampening solution between 5.5 and 4.5 Ph, but I find that the small amount of Gum Arabic in the water is adequate. Rinse your sponges. Setup the press, checking pressure, and registration on your plates.

Mixing and Modifying Ink

Polyester plates print best with inks that are moderately stiff with a fair bit of length. True lithographic inks for hand printing are very stiff and moderately short. An ink such as Daniel Smith's Crayon Black is too stiff for polyester plates and should be modified by adding a lighter varnish, such as #3, or by adding Handschy CS800 transparent base to make it more pliable for printing these plates. The Graphic Chemical Litho Black #1796 works well, but may need a

small amount of mag or #8 varnish. Color Litho inks, such as the Handschy line of inks, may work well out of the can but will often need to be modified with Magnesium Carbonate. Slowly fold it into your ink until it is mixed in well and then check the consistency to determine if it is correct. It should hold its shape as it sits on the slab rather than immediately relaxing into a blob. If the pigment 'bleeds' from your ink while printing, such as it will do with magenta and cyan, adding #8 varnish or body gum to the ink will help greatly. Color mixtures using mostly Handschy Tint Base will require more mag.

Press Setup

Printing using an etching press

Set the roller so it is just in contact or just above the press bed. It is easiest to ink your plate on a separate glass slab before printing. Once it is inked, place the dried plate face up on the center of the bed and your paper face down on the plate. Cover the plate and paper with 2 sheets of newsprint. Place an un-greased tympan on top and run everything through the press once. Felts are not needed.

Printing using a litho press

To print on a litho press, lay your plate centered and face up on the press. Place your paper on the plate according to your registration marks, and cover with two sheets of newsprint. Cover with a greased tympan and print. You should only use as much pressure as needed to pull a good impression. The plate will break down quicker if excessive pressure is used. Before you print, set up the litho press by centering your plate, setting the pressure, and marking your start and stop points (traverse marks).

Inking and Printing

Roll out your ink with a brayer so you have a satiny ink surface with a slight sizzle sound as you roll the ink. If you have too much ink the surface of the ink will look velvety and make a loud sizzling sound. 8x2.5" or 10x2.5" Brayers work well for inking polyester plates.

Lightly dampen either a glass slab or the press bed with the water and gum mixture and place your plate on the wet surface. Dampen the plate with even horizontal and vertical strokes leaving a thin film of water on the plate with no water streaks. Using a 'wet' sponge to dampen the plate and a 'dry' sponge to thin the film of water works well.

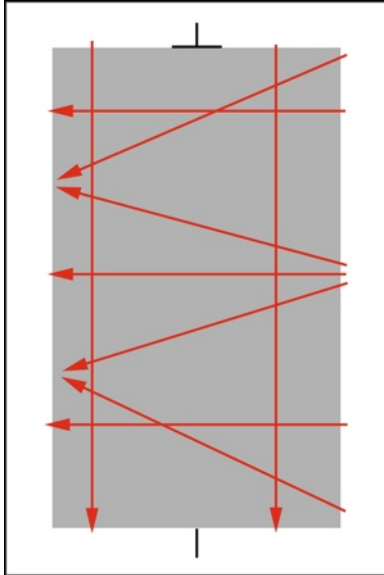

Roll from different directions to ink your image evenly.

Begin inking your plate using moderate pressure on the brayer while alternating your rolling pattern. Once you have rolled ink across the entire plate and back again, charge your brayer with more ink, dampen the plate again and complete another pass of ink from a different direction. After doing this about 3-4 times you can print a proof of your inked image on newsprint. You may find that you will need to alter your rolling pattern quite a lot and complete quite a few passes to have a fully and evenly inked image, especially if it is a dark or large image. Scumming areas and edges of the plate that have collected ink can be cleaned with a small piece of felt, toothpaste and water.

Based on the appearance of the newsprint proof you may want to add pressure, add ink, vary your inking pattern more, or continue as before printing on good paper.

Continue inking and dampening 3-5 times for each print. If your image is still light you most likely need to add ink to your slab. If it is too dark scrape ink from your slab to reduce the amount of ink you are placing on the image. If you are having a great deal of difficulty evenly inking a large, dark image, you may be using a brayer that is too small and should switch to a larger roller. A 12" wide roller works very well.

Printing Methods

Collage or Freeform Printing

You can print polyester plates using a 'free-form' collage approach, without worrying about correct registration or paper stretch. When working this way, you may find it best to print with the paper face-up and position your plate face down onto the paper. This will allow you to see where you are placing the image, and minimize the embossment from the edges of the plates. You will most likely want to wipe the edges of the plate down with a piece of felt and toothpaste to prevent the ink that has collected there from transferring to your print. I find this method works well for plates that I have cut into shapes or for a more free form approach to layering images. This method works well when using an etching press.

Registration Setup / 'T' & Bar Marks

You can put T & Bar registration marks on the back of your plates with a ballpoint pen; the marks will be visible from the printing side. You can register multiple plates easily on a light table. If you are printing multiples colors where accurate registration is critical, you will need to pre-stretch or 'calendar' your paper. This can be done by running your paper back and forth through the litho press 2 times between newsprint. Once this is done, draw your corresponding

registration marks on the back of your paper. Tear down 1 sheet of newsprint for every sheet of paper you will print, plus 4 extra sheets, all at least 1" larger than your paper.

Using an additional litho plate and pin registration

Printing your pronto plates when they are laying on top of an old litho or photo-litho plate, will help the pronto plate stay stuck down, as well as keeping the area around the plate damp and ink free. The litho plate, the pronto plates, and your paper can all be punched to use pin registration. Be sure to punch your plates face-up and the paper face down. For tight registration, pre-stretch your paper and then punch it.

Clean Up

To save a polyester plate, print it several times without inking it to remove the excess ink. Rinse the plate with water and coat with a thin layer of gum arabic. If needed you can clean it further with water and toothpaste before rinsing. The next time you want to print it, use it as you would any other polyester plate. To clean up your ink and brayers, etc:

1. Put on your Gloves.
2. Scrape the excess ink off the slab with a razor scraper and wipe it onto phone-book pages.
3. Pour a small amount of vegetable oil onto the slab. Roll the brayers in the oil until the ink begins to dissolve.
4. With a dirty rag, wipe up the oil and ink on the slab and then use the same rag to wipe down the brayers and ink knives.
5. Pour a small amount of solvent onto a fresh rag and thoroughly clean your brayers until they are spotless. Put this rag in 'Rag Hell'.
6. Use simple green and a fresh rag to clean up the oil and ink residue on the ink knives and glass slab. Also clean down the press bed and tympan with simple green.
7. Rinse out your sponges with water and clean out the bowls with a powdered cleanser if needed. Rinse out your felts too.

Thank you for leaving the studio clean and tidy for the next person!